

## DEHUMIDIFIER

# DH 92

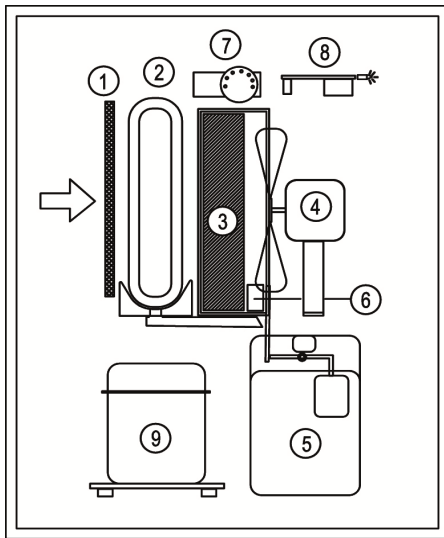

## FUNCTIONING DIAGRAM



1	:	Filter
2	:	Evaporator
3	:	Condenser
4	:	Fan
5	:	Tank
6	:	Switch
7	:	Moisture gauge
8	:	Electronic board
9	:	Compressor

## TECHINICAL DATA

Functioning Relative Humidity Range	%	<b>35-99</b>
Functioning Temperature Range	°C	<b>3 - 35</b>
Air Flow	m <sup>3</sup> /h	<b>1000</b>
Rated Condensation Capacity ( 30°C UR 80%)	l/24h	<b>80</b>
Type of Refrigerant Gas		<b>R410A</b>
Quantity of Refrigerant Gas	g	<b>850</b>
Voltage Power Supply	V	<b>220-240</b>
Frequency Power Supply	Hz	<b>50</b>
Power Consumption ( 35°C UR 99%)	W	<b>1600</b>
Absorbed Current (35°C UR 99%)	A	<b>7,1</b>
Sound Pressure Level ( at 3 mts )	dBa	<b>50</b>
Capacity of Condensed Water Tank	l/24h	<b>11</b>
Weight	Kg	<b>66</b>

## PACKING

Dimensions packing	mm	650 x 772 x 1132
Dimensions utilization	mm	580 x 600 x 1035
Pieces for Europallet	n°	1
Pieces full truck	n°	120

## PERFORMANCE

